

Superdew 3 WP

Dewpoint Hygrometer

Instruction Manual

Issue_1



UK & EU Declaration of Conformity

| | |
|---|--|
| Manufacturer | Shaw Moisture Meters (UK) Ltd Network House Lister Hill Leeds LS18 5AZ England We declare under our sole responsibility that: |
| Product & Type | Superdew 3 WP |
| Conforms to the relevant provisions of the following directives | 2014/30/EU Electromagnetic Compatibility (EMC) Directive 2014/35/EU Low Voltage Directive (LVD) |
| Compliance has been assessed by reference to the following standards | EN IEC 61326-1:2021 Electrical equipment for measurement, control and laboratory use. EMC requirements – General requirements Tested in accordance with Class A for Industrial Environments BS EN 61010-1 2010+A1 2019 Safety requirements for electrical equipment for measurement, control and laboratory use – General requirements |
| Name | Dave Thompson |
| Signed |  |
| Position | Head of Engineering |
| Date | 05/01/2026 |

Contents

| | | |
|-------------|---|-----------|
| 1.0 | Unpacking your Shaw Moisture Meters Superdew 3 WP Hygrometer | 4 |
| 2.0 | General Information | 4 |
| 3.0 | Safety Information | 5 |
| 3.1 | Warning | 5 |
| 3.2 | Isolation | 5 |
| 4.0 | Installation | 6 |
| 4.1 | Wall Mounting | 6 |
| 4.2 | Instrument Wiring | 9 |
| 4.3 | Power Supply | 10 |
| 4.4 | Alarm and Output Cable Connectors | 10 |
| 4.5 | Sensor Cable | 10 |
| 5.0 | Installing the Air/Gas Sampling System | 11 |
| 5.1 | Piping Installation Schematic | 12 |
| 5.2 | Piping Schematic Component Index | 13 |
| 6.0 | Installing and Commissioning the Sensor | 14 |
| 7.0 | Default Instrument Configuration | 14 |
| 8.0 | Programming the Superdew 3 WP | 14 |
| 8.1 | Principle of Entering Numerical Data | 14 |
| 9.0 | Configuring the Superdew 3 WP | 15 |
| 9.1 | rAngE | 15 |
| 9.2 | oUtPt | 16 |
| 9.3 | AL1 and AL2 | 16 |
| 9.4 | rS485 (Communications) | 17 |
| 9.5 | PASS | 17 |
| 9.6 | PAnEL | 17 |
| 10.0 | Normal Operation of the Superdew 3 WP | 18 |
| 11.0 | Hotkeys | 18 |
| 11.1 | Alarm Keys | 18 |
| 11.2 | Units | 18 |
| 12.0 | Automatic Calibration (Sensor Ranges up to 0 °C Dewpoint) | 19 |
| 13.0 | Automatic Calibration (Sensor Ranges up to +20 °C Dewpoint) | 19 |
| 14.0 | Monitoring the System | 19 |
| 15.0 | Faults/Errors | 20 |
| 16.0 | Guarantee | 20 |
| 17.0 | Superdew 3 WP Specification | 21 |
| 18.0 | Appendix A - Superdew 3 WP Setup Menu Flow Diagram | 22 |
| 19.0 | Appendix B - Alarm 1 & 2 Hotkey Flow Diagram | 23 |
| 20.0 | Appendix C - Units Hotkey Flow Diagram | 24 |
| 21.0 | Appendix D - rS485 Protocol | 25 |
| 22.0 | SD3 WP General Assembly Diagram | 27 |
| 23.0 | Sensor Diagram | 27 |
| 24.0 | Sensor Holder Diagram | 27 |

1.0 Unpacking your Shaw Moisture Meters Superdew 3 WP Dewpoint Hygrometer Package

Please examine the Superdew 3 WP dewpoint hygrometer package for any damage or mishandling. If any damage is evident please notify the carrier and the Shaw Moisture Meters representative from where this unit was purchased.

You should have received (if ordered):



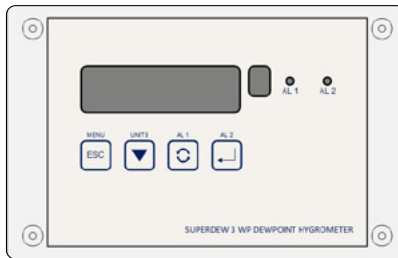

- 1 Superdew 3 WP dewpoint hygrometer
- 1 set of wall mount brackets
- 1 Shaw dewpoint sensor
- 1 connecting cable (of the length specified on your order) or two metres as standard
- 1 sensor holder
- 1 instruction manual
- 1 pressure dewpoint circular calculator

If anything is missing please contact your distributor immediately.

2.0 General Information



Every key on the Superdew 3 WP has two functions, the control function (ESC, ▼, ↻ & →) and the hotkey function (menu, units, alarm 1 and alarm 2). The use of these commands is described in the following table:

| Key | Control Function | Hotkey Function |
|--|---|---|
|  Menu | Returns the user to the previous screen, often without changing any variables. | To enter the 'setup' menu, press and hold for more than five seconds. |
|  Units | Used to decrease the selected digit when setting a numerical variable. | Enter the 'units' menu. |
|  AL 1 | Used to select the next digit when setting a numerical variable or to scroll through the options available. | Enter the 'alarm 1' menu. |
|  AL 2 | Used to confirm a numerical variable or the selection of a chosen option. | Enter the 'alarm 2' menu. |

The Superdew 3 WP:

- Wall mount trace moisture monitoring device designed to work in conjunction with the Shaw dewpoint sensor.
- The moisture content readout is displayed on a five digit, seven segment, backlit LED and available in any one of four selectable engineering units. The selected unit is indicated on a separate seven segment LED.
- Available in an AC or DC version.
- Operation is controlled by a four button membrane keypad. The user friendly software uses a simple menu selection process and incorporates three hotkeys to enable moisture levels to be read in different units, allowing quick access to both alarm settings.
- A user controllable security system.
- Includes an AutoCal potentiometer to perform automatic calibration of sensors.
- Has two full range alarms that can be set as rising or falling edge triggered. These alarms have visual indication (LEDs) and activate changeover relays for remote indication or control.
- Has a fully controllable linear 4-20 mA output.
- Includes RS485 capabilities, outputs the process variable and unit status when polled.
- Details of normal operation, engineering unit selection and configuration of the instrument are described within this manual.

3.0 Safety Information

Read the safety information **BEFORE installation**.

Clean with a damp cloth and/or mild water based detergent.

3.1 Warning

Hazardous voltages may be present on instrument terminals. The equipment must be installed by suitably qualified personnel.

3.2 Isolation

The power supply terminals and associated internal circuitry are isolated from all other parts of the equipment in accordance with EN61010-1 for connection to a category II supply (pollution degree 2). Any terminals or wiring connected to the input or output, which are accessible in normal operation, must only be connected to signals complying with the requirements for Safety Extra Low Voltage (SELV) circuits.

The mains supply to the instrument must be protected by an external 1-amp fuse and a suitable switch or circuit breaker, which should be near the instrument.

Note: *The instrument contains no user serviceable parts.*

4.0 Installation

4.1 Mounting

There are several different ways to mount the Superdew 3 WP to the wall.



Before proceeding, ensure that the product is mounted with the front panel facing horizontally, with all seals fitted including the back seal.

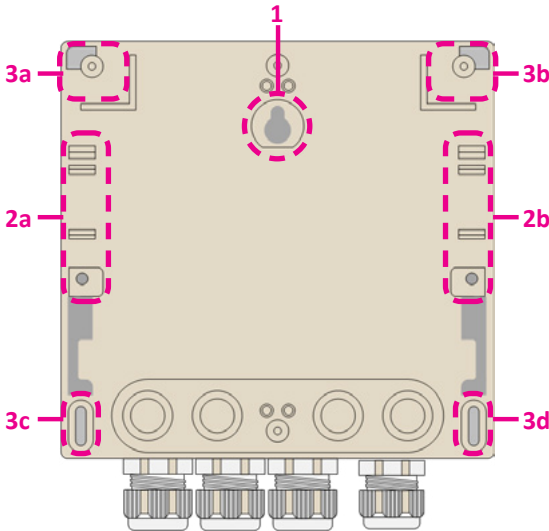

A. Hook

On the rear of the enclosure there is a hole to accept a hook or screw head for hanging. The thickness of the enclosure here is 3.7 mm therefore, the minimum gap recommended for the slot is 4 mm.



Ensure that the extremity of the hook or screw head protrudes no further than 12 mm from the wall.

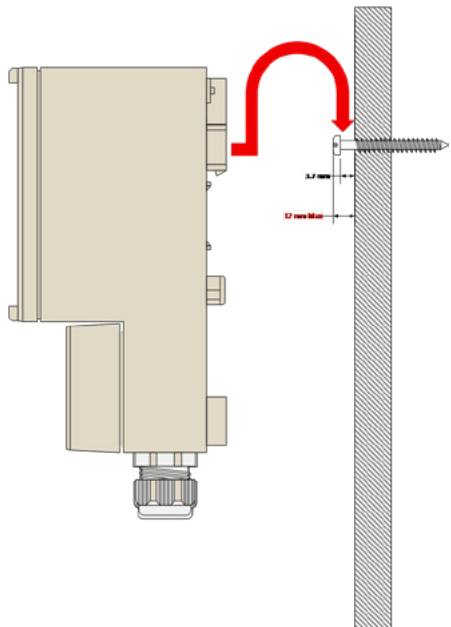

B. DIN Rail



A DIN Rail mounting kit is supplied with the instrument.

DIN Rail, type EN60715 35 mm x 15 mm, is compatible.

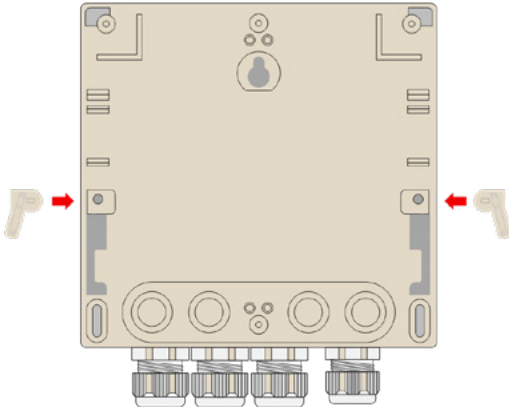

The plastic clips attach to the rear of the enclosure.

The DIN rail can then be mounted and the clips rotated to secure.

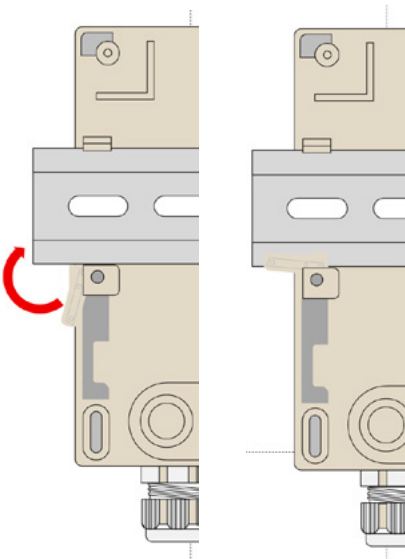

C. Wall Mount Bracket

A wall mount bracket kit is supplied with the Superdew 3 WP. The two brackets mount to the rear of the enclosure. The enclosure can then be fixed to the wall from the front using M5 screws or similar.

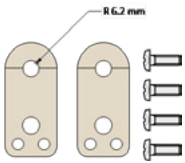

Fit the two brackets to the top of the enclosure at each corner.

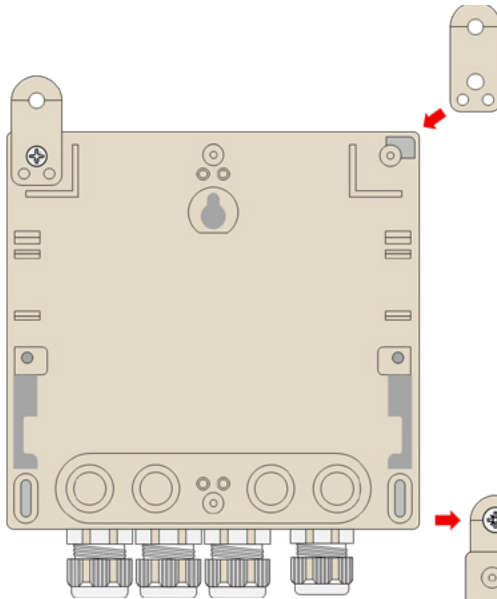

The terminal cover must be removed to mount the product to the wall.

Use M5 screws or similar to mount the product at the four mounting points shown below.

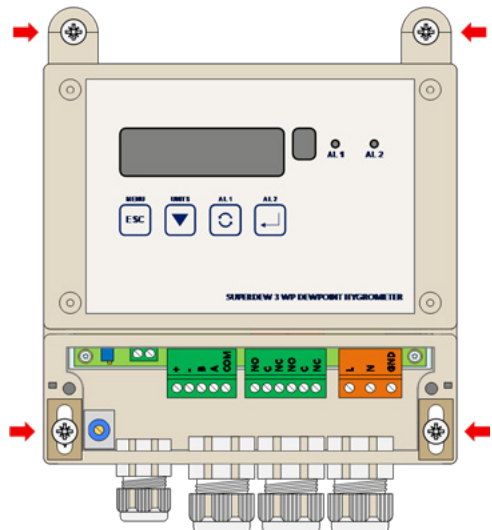

4.2 Instrument Wiring



Ensure that the power is disconnected prior to removing the terminal cover.

Remove the terminal cover by loosening the two screws. The cover should lift off while still retaining the screws.

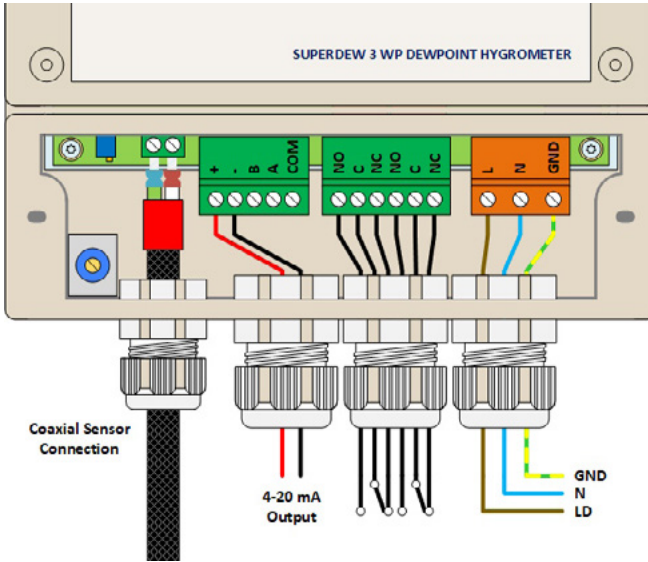

For working on the power connection, there is an additional High Voltage Guard which can be removed using the single screw in the corner. This screw will be retained with the guard.

The Main PCB connectors will now be visible.

Insert cable of the appropriate diameter through the cable gland. The cable gland on the left for the sensor connections is M16 type and the recommended cable outer diameter is 5-9.5 mm. The other three cable glands are M20 type and the recommended cable outer diameter for these is 8-13 mm.

For safety purposes, ensure the protective conductor cable connection is at least 10 mm longer than the live and neutral conductors and tighten cable glands to at least 5 Nm after installing the circuits.

In order to maintain suitable isolation, external circuits connected to this device via the dry contact relays must be derived from the same mains AC voltage and must not be connected to a separate phase. All wiring to the device must conform to local electrical regulations such as cable insulation, temperature rating and circuit fuse rating.



When wiring the electrical terminals, ensure that no more than 7 mm of insulation is removed so that strands cannot contact other terminals.

Ensure that the supplied blanking plugs are securely fitted to any unused cable glands. This will maintain the IP rating of the enclosure.

4.3 Power Supply

The Superdew 3 WP can be powered by either a 90-250 V AC or 24 V DC supply. Connect the required supply cable to the appropriate terminals as shown in fig. 1.1.

The AC power supply should be between 90-250 V AC @ 50/60 Hz.

The power supply wires are retained by screws. Ensure that the exposed section of wire is fully inserted and that no loose strands are exposed.



You must ensure:

All connector screw clamps are screwed down tightly to prevent movement of the cable.

Once the connector clamps are screwed down tightly, all cable glands are tightened to prevent movement of the cable.

A suitable, accessible and appropriately labelled circuit breaker or switch is fitted to allow the product to be isolated if needed.

4.4 Alarm and Output Cable Connectors

Connect the required cables to the appropriate terminals as shown in figure 1.1. Note: The normally open and normally closed relay contact positions and that the correct polarity and the maximum load specification are strictly observed for the analogue outputs.

Ensure that the wire is fully inserted and that no loose strands are exposed.



Ensure that all connector screw clamps are screwed down tightly to prevent movement of the cable.

Ensure that once the connector clamps are screwed down tightly that all cable glands are tightened to prevent movement of the cable.

4.5 Sensor Cable

Connect the sensor coaxial cable into the coaxial socket shown in *figure 1.1*. Route the sensor cable to the intended site of the sensor.



Ensure that all connector screw clamps are screwed down tightly to prevent movement of the cable.

Ensure that once the connector clamps are screwed down tightly that all cable glands are tightened to prevent movement of the cable.

5.0 Installing the Air/Gas Sampling System

The *Piping Installation Schematic* diagram (see section 5.1) shows all components that could be used in a dry gas measurement application. Not all the items shown will be required for every installation.

Care should be taken to ensure that the sample presented to the measuring sensor is not contaminated with any other component that will damage, contaminate or affect the sensor in a way that will impair the system accuracy.

It is strongly recommended that the sample should not contain particulate matter, oil or other heavy hydrocarbon condensate. If these components contaminate the sample system and/or the measuring sensor, the system response time will be lengthened, although the sensor calibration will not be effected.

The sample must not contain Ammonia, Chlorine, Ozone or any wet acid vapours or liquid as these will permanently damage the sensor and impair calibration accuracy.

The flow rate, although not critical to the sensor measurement, should be low enough to avoid abrasion to the sensor surface without being so low as to extend the system response time to an unacceptable level. In general, a flow rate of between 2 and 3 litres/min at NTP will give the right balance.

The sensor is a variable capacitor, which is directly affected by changes in partial pressure of water vapour and these changes that are proportional to the dew/frost point temperature are displayed on the instrument indicator.

The measuring sensor can be installed directly into the process line but this may create problems with access for maintenance and calibration. It is for these reasons that we recommend that the sensor will be installed in a bypass, fast loop or total loss sample system where the sensor is accessible without interrupting the main process flow line.

5.1 Piping Installation Schematic

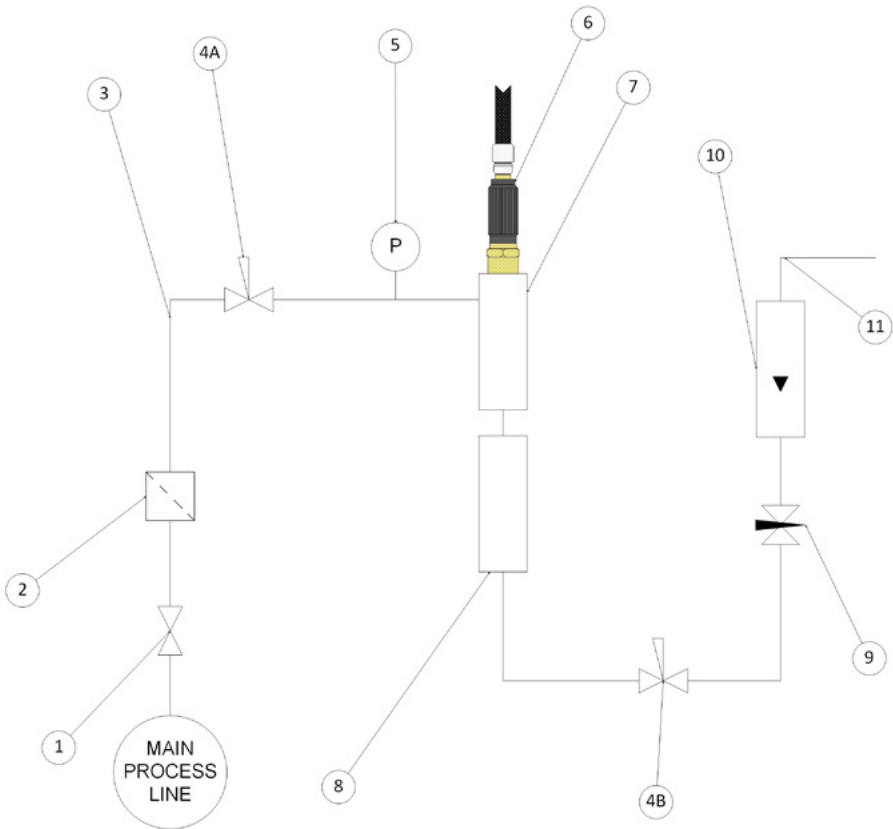

Notes

- The sample pipe should not be on the upper surface of the horizontal pipe or on a vertical section of pipe wherever possible.
- The sample tube should run continually upwards from the sample point. If this is not possible then an inspection port or drain tap should be installed at the lowest point in the system.

5.2 Piping Schematic Component Index

1. **Sample Isolation Valve** - This is a recommended item as it allows access to the sample system without interrupting the main process line.
2. **Filter Unit** – A filter unit is recommended when the samples are likely to contain particulate matter. If the air/gas sample contains heavy hydrocarbon condensate, the filter must be of the coalescing type with a drain. The filter unit should be positioned as close to the sample point as practical.
3. **Sample Tube** – This should be stainless steel for dry air or gas applications but copper or carbon steel can be used where wetter gases are to be measured. If any section of the sample tube must be flexible then PTFE should be used. In most cases, 3 mm OD ($\frac{1}{8}$ ") is sufficient as it provides good system response time within minimum flow. 6 mm OD ($\frac{1}{4}$ ") tube can be used where pressure drops are too high.
4. **Pressure Reduction Valve or Pressure Regulator** – If the sample is to be measured at atmospheric pressure then the valve 4A should be fitted and 4B omitted from the system. If the sample is to be measured at full line pressure and the exhaust vented to atmosphere, then valve 4B should be fitted and 4A omitted from the system. If measurements are to be taken at full line pressure and the sample is to be returned to a part of the main line or a vent, which is at a pressure higher than atmospheric, and the input to that line needs a controlled pressure then both 4A and 4B will be required.
5. **Sample Pressure Gauge** – This is not a critical part of the moisture measurement but may be required if dew/frost point measurements are to be made at higher than atmospheric pressure.
6. **Measuring Sensor**
7. **Sensor Holder**
8. **Desiccant Chamber** – This item is required when the sampling is to be intermittent. When installed it prevents the ingress of wet air to the sample system, while the sample is not flowing, improving the response time.
9. **Flow Control Valve** – This can be a separate item or combined with the flow indicator.
10. **Flow Indicator** – The recommended sample flow is 2 to 3 SL/M.
11. **Sample Exhaust** – The exhaust can be vented to atmosphere or returned to the process line as discussed above.

6.0 Installing and Commissioning the Sensor

It is advisable to carry out an initial purge routine of the sample loop before installing the sensor. This is to remove the possibility of sensor damage on start up.

Refer to the *Piping Installation Schematic* in section 5.1.

Open the inlet isolation valve slowly until a small flow of air/gas (at atmospheric pressure) flows through the inlet pipe work to the sensor holder, exhausting through the sensor entry port of the sensor holder.

Allow this purge to continue for about 15 - 20 minutes to remove any residual moisture from the sample pipe work and components.

Close the inlet isolation valve and install the sensor into the sensor holder. Locate and connect coaxial cable in position on the sensor.

Open the inlet valve slowly, by opening all valves after the sensor holder, allow a low pressure purge through the whole sample system.

Note: If a closed by-pass loop is installed, this section of the procedure is not possible. Set the required flows within the sample loop.

This completes the installation and commissioning but on initial start up, it could take several hours for the system to reach equilibrium. The Superdew 3 WP will now indicate the dewpoint of the air/gas surrounding the sensor and the analogue output will give mA signals proportional to the indicated dewpoint.

7.0 Default Instrument Configuration

The standard factory settings are as follows:



- The instrument will display the moisture content in °C dewpoint
- Both alarms are set to trigger when rising above the upper limit
- The output span is set to 4-20 mA
- The 4-20 mA output is set to the full span of the selected range
 - e.g. 4 mA = -80 °C
 - 20 mA = 20 °C
- All security codes are defaulted to 0000







8.0 Programming the Superdew 3 WP

8.1 Principle of Entering Numerical Data

See *Appendix A, B & C* for flow charts.

The  key allows the user to leave a part of the menu without changing any settings.

Wherever a numerical value has to be entered into the Superdew 3 WP, the following text will be found. "Use the ,  &  keys to enter.....". The basic principle used to enter numerical values (integer or floating point) is described here.



The first character of the LCD display flashes to indicate it is active. Use the  key to select the required number between 0 and 9 (plus the minus sign) then press the  key to make the second character flash. Again, use the  key to select the required number between 0 and 9, press the  key to make the third character flash etc.. Continue this process until all characters are entered. In the case of a floating point numbers in lb/MMSCF or ppm, pressing the  key again makes the decimal point (dp) active. Use the  key to position the dp in the required position. Pressing the  key at any point confirms the numerical value. °C and °F are fixed to 1 dp.

Note: The password used within the Superdew 3 WP is made of four integers and does not use the dp.

Note: To leave the numerical part of this routine without saving, simply press the  key.

9.0 Configuring the Superdew 3 WP

See *Appendix A*.





Operation: To enter the setup menu press and hold the  key for five seconds. This will display the 'SETUP' message on the LED as in the Superdew 3 WP Setup Menu Flow Diagram (see *Appendix A*). Pressing the  key again enters the setup menu map at the 'rAngE' option on the top level. There are seven top level options described.

Note: The default setup will go directly from the SETUP message to the rAngE screen. However, if the user has set a password, then the user is prompted to enter the correct password before continuing on to the top level.

Note: Most of the screens within the menu have an active 10 second time-out. Therefore, if no keys are pressed within this period the unit reverts automatically to normal operation. In most cases where the 10 second time-out occurs, changes will not have been saved.

9.1 rAngE

Description: The 'rAngE' option allows the user to select the required sensor range. This option is used to match the Superdew 3 WP to the sensor connected to the unit. For example a 'RED' sensor requires that the Superdew 3 WP 'rAngE' option 'rEd' is selected.



While 'rAngE' is displayed press the  key to enter the subroutine. The  display now shows the currently selected sensor range. Use the  key to scroll through the options until the required range is displayed. Press the  key to select the new range. The message 'Conf' will be displayed. Press the  key again to confirm selection.



Pressing the  key at any time reverts to the 'rAngE' screen without saving any change.



See *Superdew 3 WP Specification (pg 22)* for detailed information on ranges.

9.2 oUtPt

Description: The 'oUtPt' option of the Superdew 3 WP allows the user to set the span and the range over which the 4 - 20 mA operates. The default setting is for the output to cover the full operating span of the selected range e.g. 4 mA to equal -100 °C and 20 mA to equal 0 °C. It is possible to set a more focused span, such as 4 mA to equal -60 °C and 20 mA to equal -20 °C. It is also possible to select 0 - 20 mA as well as 4 - 20 mA.

Operation: While 'oUtPt' is displayed press the  key to enter the subroutine. The display now displays 'SPAn' use the  key to select either 'Hi', 'Lo' or 'SPAn' then press the  key.



Note: If the  key is pressed the **Superdew 3 WP** will return to the 'oUtPt' screen.
If the 'SPAn' option is selected, use the  key to select the required span (0 - 20 mA or 4 - 20 mA). Press the  key to confirm selection.

If either the 'Lo' or 'Hi' options are selected the screen will now display the current High or Low range value. Use the  &  keys to enter the new value. Press the  key to confirm and **save** the new value. The other range limit can now be set by following the same process.

Once the  key is pressed to set either the high or low range limit that value is written to memory and will not revert to the previous value even if the 10 second time-out occurs.

9.3 AL1 and AL2

Description: The AL1 and AL2 option allows the user to set up two independent alarms. Trip point, direction of trigger' relay enable status, latching status and hysteresis can be set within this option.

Operation: While 'AL1' or 'AL2' are displayed press the  key to enter the subroutine. The LED now displays 'SEtPt'. Use the  key to select the required function and then press the  key.

Note: If the  key is pressed the **Superdew 3 WP** will return to the 'AL1' or 'AL2' screen.

Depending on the option selected, the user will now be able to perform the following functions:

'SEtPt' Enter the alarm set point.

'tYPE' Select if the alarm is to activate on a rising signal 'Hi', falling signal 'Lo' or 'OFF'.

'rELAY' Select if the relays are energised 'En' or de-energised 'dE-En'

'LAtCh' Set if the alarm is latch 'YES' or not latching 'nO'.



9.3 AL1 and AL2

'HYST' Enter the hysteresis value.



Note: Once the  key is pressed to set any of the alarm parameter, that value is written to memory and will not revert to the previous value even if the 10 second time-out occurs.

9.4 rS485 (Communications)

Description: The rS485 option allows the user to set the **Superdew 3 WP** address and communication baud rate used when the **Superdew 3 WP** is communicating with a PC using rS485 point-to-point communications.



Operation: While **'rS485'** is displayed press the  key to enter the subroutine. The display now displays **'Addr'** use the  key to select either **'Addr'**, or **'bAUd'** then press the  key.

Note: If the  key is pressed the **Superdew 3 WP** will return to the **'rS485'** screen.

If the **'Addr'** option is selected the screen will now display the current address value. Use the  &  keys to enter the new value. Press the  key to confirm and **save** the new address.

Note: Once the  key is pressed to set the address, that value is written to memory and will not revert to the previous value even if the 10 second time-out occurs.





Note: Legal addresses are 1 to 32.

If the **'bAUd'** option is selected, use the  key to select the required baud rate (9600, 4800, 2400 or 1200). Press the  key to confirm selection.

For rS485 Protocol please *see Appendix B*



9.5 PASS

Description The PASS option allows the user to alter the security password used to protect the **'SetUP'** menu.

Operation While **'PASS'** is displayed press the  key to enter the subroutine. The LCD now displays **'0000'**. Use the ,  &  keys to enter the new password.

9.6 PANEL

Description: The PANEL option allows the user to restrict the functions of the front panel hotkeys. If the **'On'** option is selected, the hotkeys are unrestricted.

Operation: While **'PANEL'** is displayed, press the  key to enter the subroutine. The LCD now displays **'On'** or **'OFF'**. Use the  key to select **'On'** or **'OFF'**. Press the  key to confirm selection.

10.0 Normal Operation of the Superdew 3 WP

In normal operation, the **Superdew 3 WP** will display the current moisture value of the connected sensor. The value is displayed in the currently selected engineering units, which is indicated by the small LED.

The alarm LEDs (AL1 and AL2) will light whenever an alarm condition occurs and only turn off when the alarm condition clears.

Remote signalling of an alarm condition is provided by two internal changeover relays that trigger at the same time as the LEDs.



11.0 Hotkeys





11.1 Alarm Keys

See Appendix C

Description The 'AL1' and 'AL2' hotkeys allow the user to review and alter the alarm trigger points without interrupting the monitoring process.

If the hotkeys are restricted by the 'PANEL' function then the alarms can only be reviewed.

Operation To review the alarm trip point press the  (AL1) or  (AL2) key momentarily. The screen will display the set trip point for two seconds before reverting to the dewpoint reading.



To alter the trip point press and hold the  (AL1) or  (AL2) keys for longer than five seconds. The screen will display and allow the user to alter the trip point using the ,  &  keys.

11.2 Units

See Appendix D

Description The 'Units' hotkey allows the user to review and alter the displayed units.

If the hotkeys are restricted by the 'PANEL' function then the units can only be reviewed. If the  key is pressed to select another moisture unit, the **Superdew 3 WP** will display 'LOC' and not change the moisture units.

Operation To review the **Superdew 3 WP** moisture units press the  (Units) key for longer than five seconds. The screen displays the current moisture reading in the currently selected moisture units. Press the  key to scroll through the current moisture level in each of the moisture units. Press  key to select a different moisture unit.

12.0 Automatic Calibration (Sensor Ranges up to 0 °C Dewpoint)

Calibration is only to be carried out by trained maintenance personnel. Opening the cover or performing calibration functions exposes the AC power supply terminals and should only be carried out in a clean environment free from dust and rain.

The system relies on the fact that each sensor is designed to give no further increase in reading when it reaches its maximum moisture level. This means that, for instance, the Silver Spot or Red Spot sensor will read –20 °C dewpoint when it is exposed to gas at –20 °C dewpoint but will continue to read -20 °C dewpoint when it is exposed to wetter gas. The system can therefore be calibrated very simply by exposing the sensor to anything wetter than –20 °C dewpoint and adjusting the reading to that point on the display. For the Grey Spot sensor the maximum level is 0 °C DP and the same principle applies.

In practice, an AutoCal is performed as follows:-

1. Ensure the Superdew 3 WP is powered up.
2. Remove the sensor from the sensor holder and expose it to ambient conditions for at least one minute.
3. Check the Superdew 3 WP reading. It should display the maximum level of dewpoint for the instrument (i.e. -20 °C for Red and 0 °C for Grey).
4. If the unit is reading incorrect then use a small screwdriver to turn the AutoCal potentiometer (found under the terminal cover) clockwise to increase the reading (wetter) or anticlockwise to decrease it.

13.0 Automatic Calibration (Sensor Ranges up to +20 °C Dewpoint)

In order to calibrate a +20 °C sensor, it is necessary to measure the ambient air dewpoint by some other method. Careful use of a sling or whirling hygrometer can achieve accurate results or a cooled mirror device can be used.

The following procedure should be used:

1. Ensure the Superdew 3 WP is powered up.
2. Remove the sensor from the sensor holder and expose it to ambient conditions for at least one minute.
3. Compare the reading of the Superdew 3 WP in the ambient air, against the actual moisture level obtained by another method. Turn the AutoCal potentiometer (found under the terminal cover) using a small screwdriver clockwise to increase the reading (wetter) or anticlockwise to decrease it.

14.0 Monitoring the System

The system is designed to operate continuously with a minimum amount of operator input.

It is, however, advisable to inspect the sample loop periodically to ensure that the required flows are being maintained.

The number and type of items employed in the sample loop will determine what, if any, other routine checks should be made. If, for instance, a filter is used, the filter element should be inspected periodically and changed when necessary.

The instrument should not require any routine maintenance but if any malfunction is suspected, it is advisable to contact your local dealer.

Should it be necessary at any time or for whatever reason, to change either the instrument or sensor, it should be noted that the components of the Superdew 3 WP sensor system are completely interchangeable. If the product or a component becomes defective, only use genuine replacement parts from the original manufacturer or your distributor. Any faulty items should be returned for repair or rework.

If the equipment is used in a manner not specified by the manufacturer, the protection provided by the equipment may be impaired.

15.0 Faults/Errors

If the sensor is short-circuited the display will read '**Short**', the voltage output will drive to full scale, the current output will drive to 20.25 mA and both alarms/relays will trip.

If the user tries to enter an alarm level above the maximum value of the sensor range selected, the Superdew 3 WP will display '**oVER**'.

16.0 Guarantee

All Shaw products are guaranteed for two years from the date of purchase, some exclusions are as follows:

Removing protective guard from any sensor, subjecting sensor to shock or black list gases e.g. caustic and acidic gases like ammonia and chlorine, tampering with any internal electronics and applying incorrect supply voltage to meters, subjecting to excessive flow rate, contaminants and general misuse.

If you suspect a fault which you feel needs to be attended to under guarantee please contact us for assistance hopefully to help fault find and effect a remedy and if this is not successful to give precise instructions for the return for inspection.

No equipment will be replaced or repaired without having been returned for inspection either to ourselves or an authorised distributor.

17.0 Superdew 3 WP Specification

| Superdew 3 WP | ELECTRICAL |
|---|---|
| <ul style="list-style-type: none">● Sensor SHAW Ultra High Capacitance Aluminium Oxide Sensor● Ranges P (Purple): -100 °C to 0 °C dewpoint 0-6,000 ppm(V) S (Silver): -100 °C to -20 °C dewpoint 0-1,000 ppm(V) G (Grey): -80 °C to 0 °C dewpoint 0-6,000 ppm(V) R (Red): -80 °C to -20 °C dewpoint 0-1,000 ppm(V) B (Blue): -80 °C to +20 °C dewpoint 0-23,000 ppm(V)● Approvals CE and UKCA ● AutoCal Field calibration/span check facility. Activated and operated via potentiometer underneath the terminal cover of the instrument.● Factory Calibration Supplied with Certificate of Calibration traceable to the National Physical Laboratory (NPL)● Accuracy ±2 °C (±3.6 °F) dewpoint NPL traceable -90 °C to +20 °C (-130 °F to +68 °F)● Resolution 0.1 °C, 0.1 °F dewpoint or 0.1 ppm(v)● Repeatability Better than ±0.3 °C (±0.54 °F) dewpoint● Operating Temperature -20 °C to +60 °C (-4 °F to +140 °F)● Storage Temperature -20 °C to +70 °C (-4 °F to +158 °F)● Response Times Wet to dry: -20 °C to -60 °C - less than 120 secs Dry to wet: -100 °C to -20 °C - less than 20 secs● Sample Flow Rate Flow independent but ideally 2 - 5 litres per minute Max: 25 litres/min● Calibration Warranty 12 months from date of dispatch | <ul style="list-style-type: none">● Electromagnetic Compatibility (EMC) Immunity: Complies with EN 61326:2021 Emissions: Complies with EN 61326:2021● Warm Up Time 5 seconds● Fault Conditions Short circuit/over range: display reads “Short” and output drives to 20.25 mA● Output Signal Isolated 4 - 20 or 0 - 20 mA Linear● Operating Voltage 90 to 250 V AC 50/60 Hz or 24 V DC● Display 5 character LED● Alarms Two single pole changeover contacts (NO/C/NC), rated at 10 A at 240 V AC. Alarm trip at set point with 0.1 °C (or equivalent) hysteresis to eliminate relay chatter● Cable Supplied with two metre low loss coaxial cable |
| | <h3 data-bbox="572 802 1034 842">MECHANICAL</h3> <ul style="list-style-type: none">● Operating Pressure From 1kPa (0.01 barA) to maximum 35,000 kPa (350 barA)● Operating Humidity (External) Maximum - 95% RH non-condensing● Enclosure 166 mm wide, 186.5 mm high by 88.5 mm deep PC case● Mounting Wall or DIN Rail (EN 60715 35 x 7.5 mm) mount● Sensor Protection 316 sintered stainless steel filter - 50 micron● Probe Material (Wetted Parts) 316 stainless steel● Weatherproof Classification IP65● Mechanical Warranty 24 months in case of faulty workmanship and defective parts |

18.0 Appendix A - Superdew 3 WP Setup Menu Flow Diagram

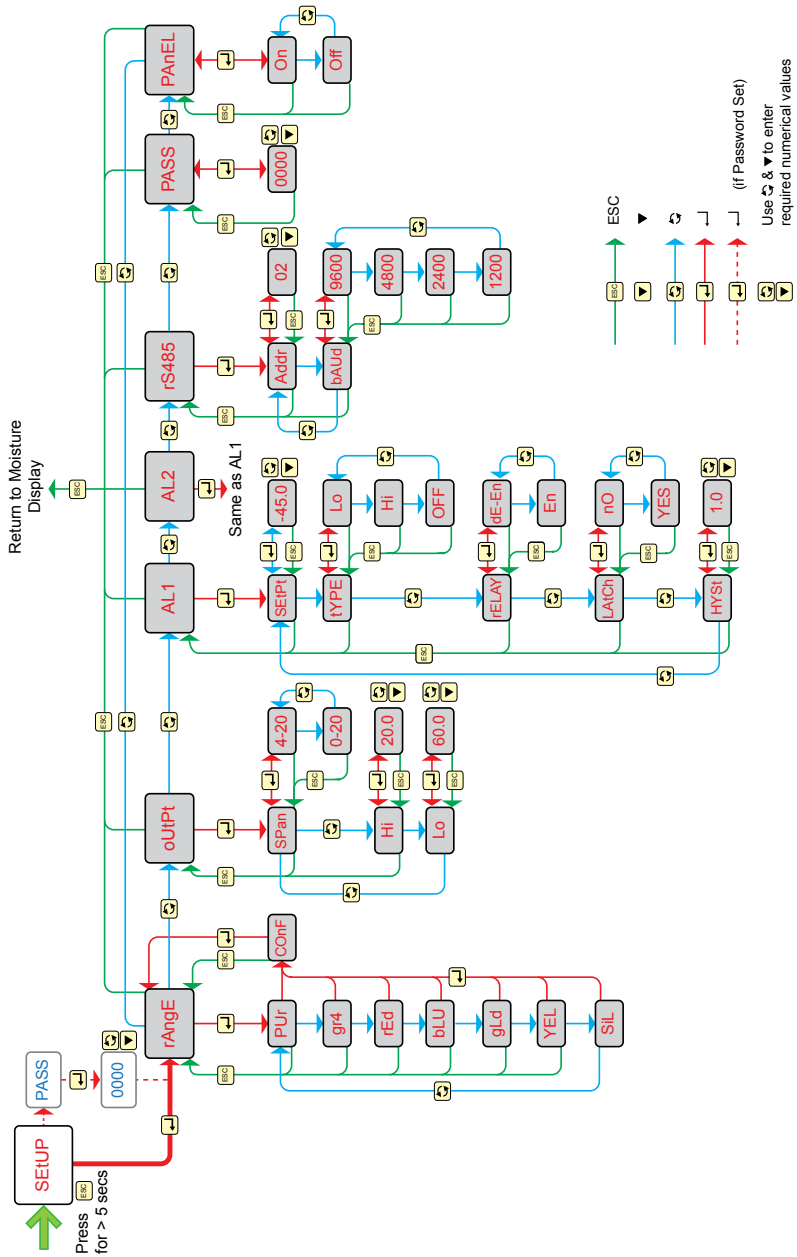

19.0 Appendix B - Alarm 1 & 2 Hotkey Flow Diagram

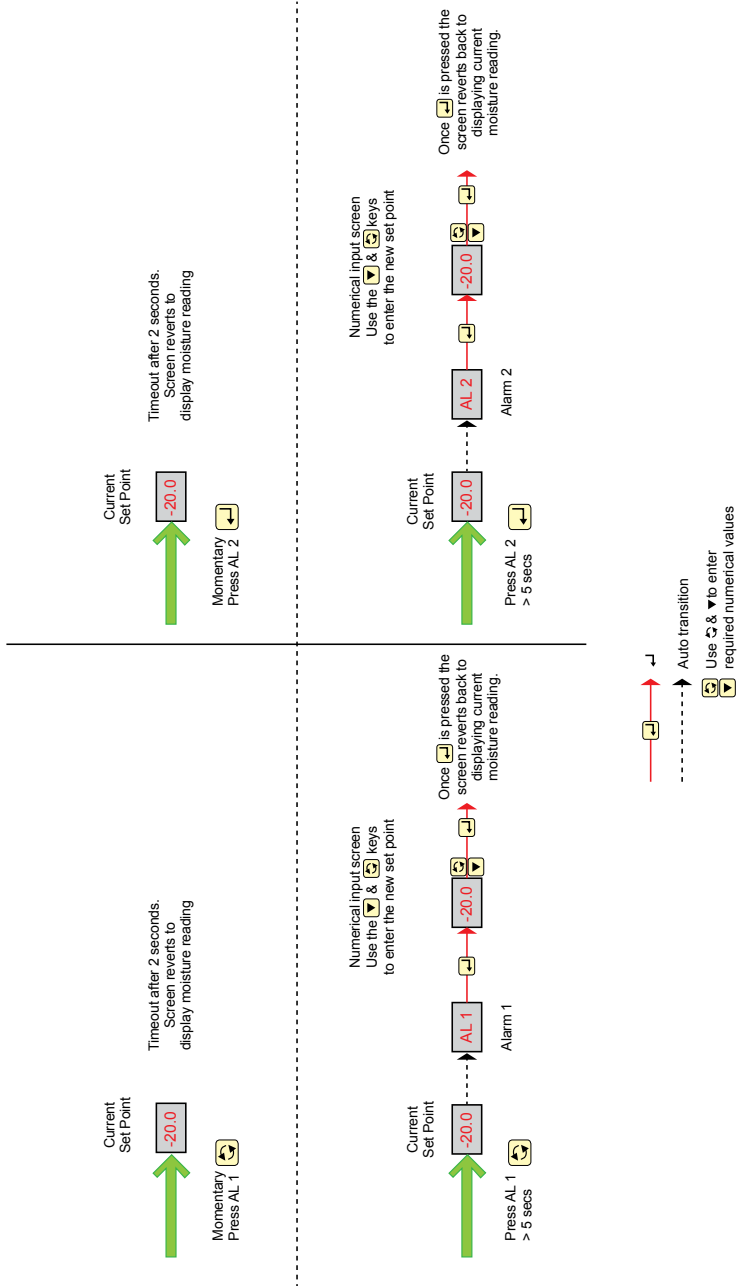

20.0 Appendix C - Units Hotkey Flow Diagram

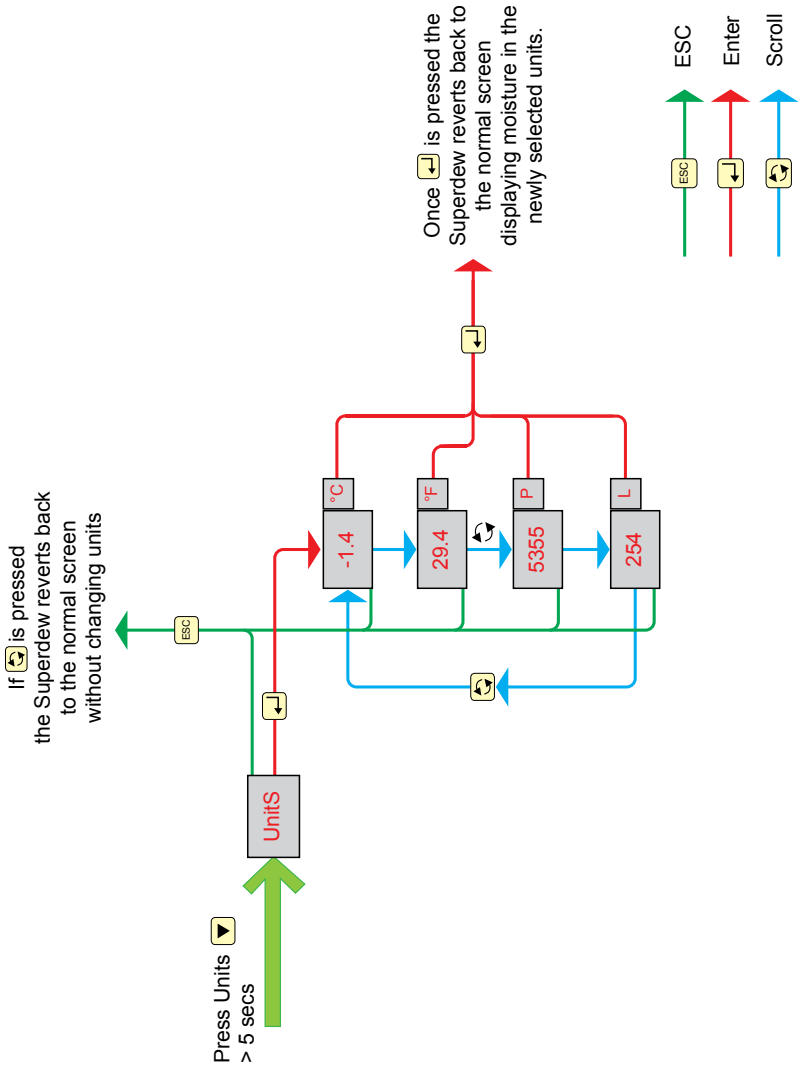

21.0 Appendix D - RS485 Protocol

Data Collection System Output

Overview

1. rS485 interface is required.
2. Baud rate and address are set from the front panel.
3. Data Bits = 8, Parity = none, Stop Bits = 1, Flow Control = none.
4. All transmission is binary (i.e. a byte represents 0 to 255 NOT ASCII characters).
5. A Hart-like protocol is used.
6. A single Superdew 3 WP may be connected using the universal address of 0.
7. Up to 32 separate Superdew 3 WP instruments may be connected using address 1 to 32 (NOT including the universal address of 0).
8. Superdew 3 WP is the slave3 and must be polled for data.
9. There is only one command and that returns the process value in the units set from the front panel.
10. Alarm state and a sensor short are returned in a 2-byte status word.

Details

| rS485 Receive Protocol (as seen by Superdew 3 WP) | | |
|---|------------------|---|
| Byte | Description | |
| 0, first | Preamble | 255 |
| 1 | | 255 |
| 2 | | 255 |
| 3 | | 255 |
| 4 | | 255 |
| 5 | Client-to-Server | 2 |
| 6 | Address | 0 to 32 |
| 7 | Command | 24 |
| 8 | Data Length | 1 |
| 9 | Data Bytes | 0 |
| 10, last | Checksum | 8-bit Arithmetic Exclusive-or of bytes 5 to 9 |

| rS485 Transmit Protocol (as seen by Superdew 3 WP) | | |
|--|------------------|--|
| Byte | Description | |
| 0, first | Preamble | 255 |
| 1 | | 255 |
| 2 | | 255 |
| 3 | | 255 |
| 4 | | 255 |
| 5 | Server-to-Client | 6 |
| 6 | Return Address | 8-bit Arithmetic Or of Address with 128 |
| 7 | Command | 24 |
| 8 | Data Length | 6 |
| 9 | Status | bits 15 - 8 |
| 10 | | bits 7 - 0 |
| 11 | Data | Process Value |
| 12 | | Single Precision (4-Byte Float) |
| 12 | | IEEE 754 Format |
| 14 | | Big-endian (first byte = ms) |
| 15, last | Checksum | 8-bit Arithmetic Exclusive-Or of bytes 5 to 14 |

| Transmit Status | | | |
|-----------------|---------------------------|------------------------------------|------------------------|
| Bit | Description | | |
| 15, first (ms) | Not defined | Poll message sent to Superdew 3 WP | 255 |
| 14 | | | 255 |
| 13 | | | 255 |
| 12 | | | 255 |
| 11 | | | Alarm 2: user to clear |
| 10 | Alarm 1: user to clear | | 0 |
| 9 | Alarm 2 | | 24 |
| 8 | Alarm 1 | | 1 |
| 7 | Not defined | | 0 |
| 6 | Sensor short | | 27 |
| 5 | Not defined | Reply transmitted by Superdew 3 WP | 255 |
| 4 | | | 255 |
| 3 | | | 255 |
| 2 | | | 255 |
| 1 | | | 255 |
| 0, last (ls) | | | 6 |
| | | | 128 |
| | 24 | | |
| | 6 | | |
| | 0 | | |
| | 0 | | |
| | <4 bytes of single float> | | |
| | <1 byte of checksum> | | |

22.0 SD3 WP General Assembly Diagram

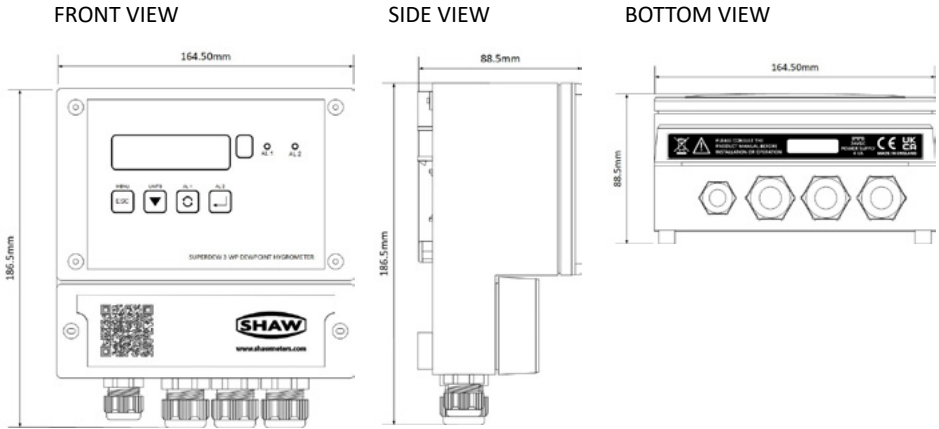

23.0 Sensor Diagram

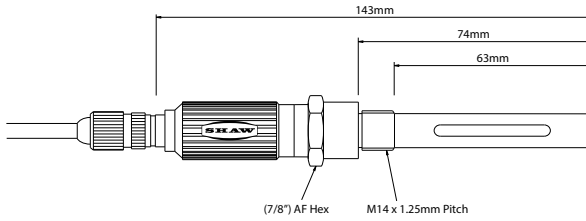

24.0 Sensor Holder Diagram

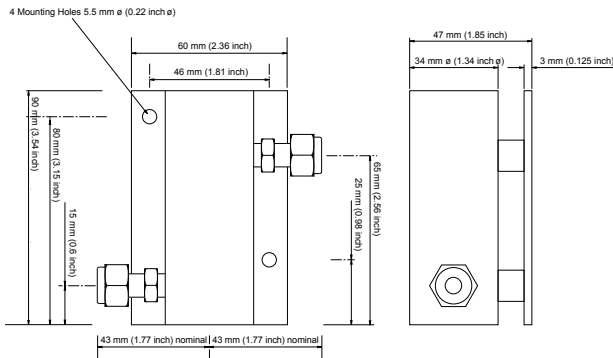

NOTE: The assembly is shown with 1/4 inch OD tube fittings. The dimension across the tube fittings will vary for all other size fittings.

